

**HOBART**701 S Ridge Avenue, Troy, OH 45374  
1-888-4HOBART • www.hobartcorp.com**HGC18 SERIES  
GAS PIZZA OVEN****HOBART****STANDARD FEATURES**

- Stainless Steel Front, Sides and Top
- 18" Deep Baking Chamber, 3¾" Product Clearance
- Stainless Steel Conveyor Belt –  
58" L - HGC30  
68" L - HGC40
- Reversible Belt Drive with Variable Speed Controls
- High Efficiency Gas Power Burner  
50,000 BTU/hr. - HGC3018  
60,000 BTU/hr. - HGC4018
- Electronic Temperature Controls with Digital Read-Outs
- High Velocity Precision Targeted Air Flow for Consistent, Repeatable Baking Results
- Removable Stainless Steel Crumb Trays and Front Access Panel for Ease of Cleaning
- ¾" Rear Gas Connection and Combination Gas Control Valve
- 6 ft. Cord and Plug, 120/60/1, 7.9 amps
- 4" Stainless Steel Legs

**OPTIONS AT EXTRA COST**

- 4' Flexible Gas Hose with Quick Disconnect and Restraining Device

**ACCESSORIES**

- 24" Stainless Steel Stand with Locking Casters for Single Oven or Double Stack Oven

**MODELS**

- HGC3018 — Gas Pizza Oven 30"l x 18"d
- HGC4018 — Gas Pizza Oven 40"l x 18"d

Specifications, Details and Dimensions on Reverse Side.

**HGC18 SERIES GAS PIZZA OVEN**

# HGC18 SERIES GAS PIZZA OVEN



701 S Ridge Avenue, Troy, OH 45374  
1-888-4HOBART • www.hobartcorp.com

## DETAILS AND DIMENSIONS

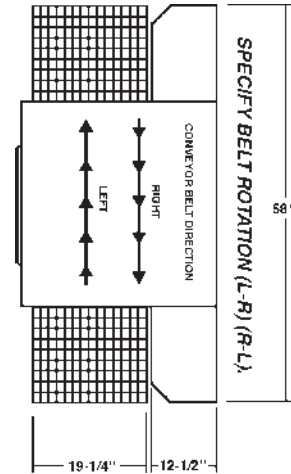
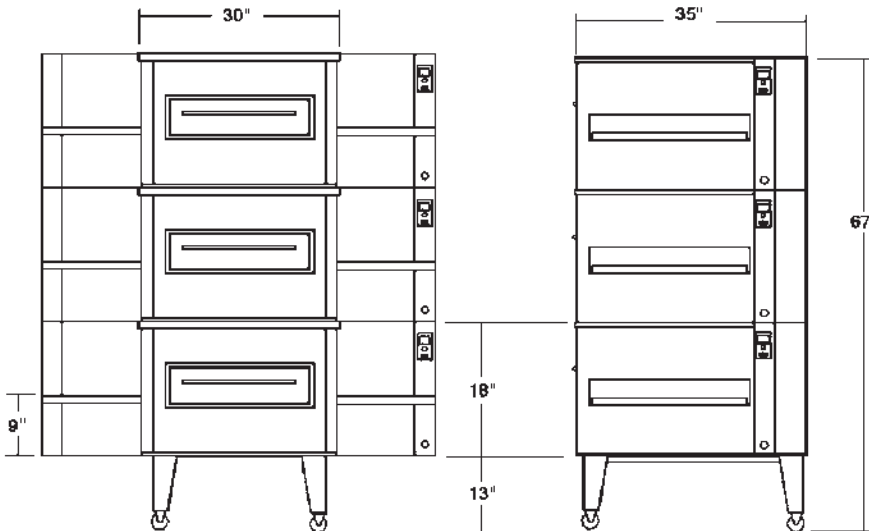
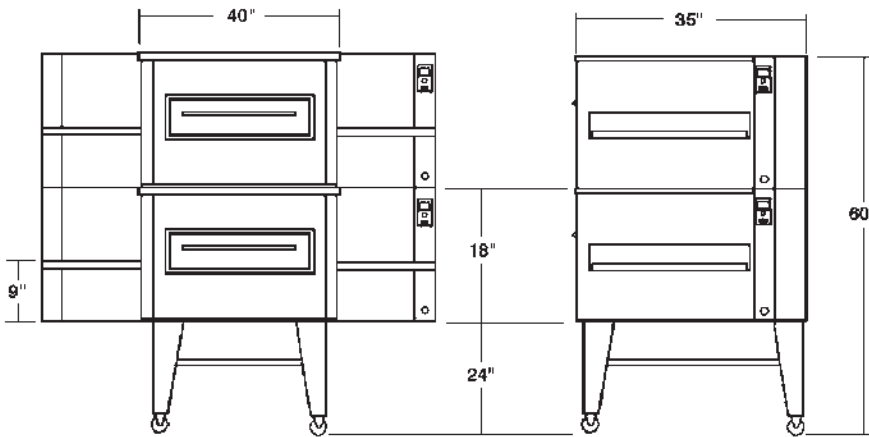
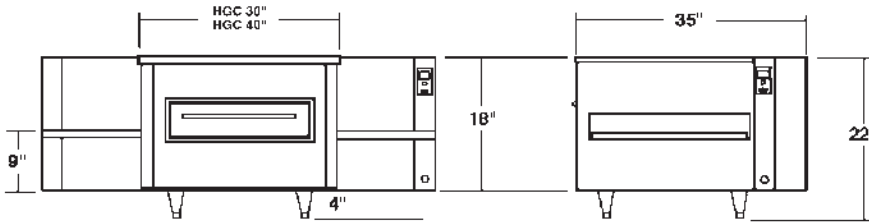

### IMPORTANT

1. A combination gas control valve sized for this unit is included. Natural gas 7" W.C., propane gas 11" W.C.
2. Gas line connecting to range must be 3/4" or larger for a single oven, 1" or larger for a double stack oven and 1 1/4" or larger for a triple stack oven. If flexible connectors are used, the inside diameter must be at least the same as the iron pipe and rated for the correct gas input.
3. An adequate ventilation system is required for commercial cooking equipment. Information may be obtained by writing to the National Fire Protection Association, Batterymarch Park, Quincy, MA 02289. When writing, refer to NFPA No. 96.
4. These units are manufactured for installation in accordance with ANSZ223.1A (latest edition). National Fuel Gas Code. Copies may be obtained from the American Gas Association, 1515 Wilson Blvd., Arlington, VA 22209.
5. Clearances:
 

	Combustible	Non-comb.
Rear	2 1/2"	2 1/2"
Sides	2 1/2"	2 1/2"
6. This appliance is manufactured for commercial installation only and is not intended for home use.

MODEL	EXTERIOR DIMENSIONS	BELT DIMENSIONS	ELECTRIC	B.T.U.	APPROX. SHIP. WT.
HGC3018	58"l x 42"d x 22"h	18"w x 58"l	120V / 7.9 amps	50,000	425 lbs.
HGC4018	68"l x 35"d x 22"h	18"w x 68"l	120V / 7.9 amps	60,000	450 lbs.

\* Single oven on 4" legs      \*\* On 24" stainless steel stand.

As continued product improvement is a policy of Hobart, specifications are subject to change without notice.